

T-690 & T-690 MAX SPECIFICATIONS

T-90 SERIES... EXPECT MORE.

Since 1938, Thermo King's priority has been to develop innovative products that meet and exceed the ever changing needs of our customers.

The development of the T-90 Series of transport refrigeration units for straight trucks continues the legacy of customer-focused innovation. Taking our self-powered truck refrigeration models to a new level, the next-generation T-90 Series offers the right solutions for today's challenges. Whether you're looking for more capacity, trustworthy reliability and performance, fuel efficiency, unprecedented temperature pull-down and recovery, convenient maintenance intervals, or all of the above, the T-90 Series will not let you down. And now with the integration of our ConnectedSuite™ telematics package and the standardization of our premium HMI included, you truly get MORE WITH THERMO KING.



KEY OPTIONS

Customize your unit to fit your business needs:

- SmartPower™ Electric Standby (230V and 460V)
- Whisper® Noise Reduction
- Top Screen
- Snow Cover
- Solar panels (40W and 110W options)
- Electronic Door Switches
- Body Mount HMI
- TouchPrint Premium
- Arctic Package
- Monitor Package

SYSTEM PERFORMANCE

Refrigeration capacity: System net cooling capacity at 100°F ambient temperature and high speed engine/60 Hertz electric power

| Return air to evaporator | T-690 | | | T-690 MAX | | |
|---|----------------------------|--------|-------|----------------------------|--------|-------|
| | 35°F | 0°F | -20°F | 35°F | 0°F | -20°F |
| Engine power BTU/hr (Up to) | 19,000 | 12,000 | 7,250 | 21,000 | 13,500 | 8,000 |
| Electric power BTU/hr (Up to) | 16,500 | 11,000 | 6,500 | 18,000 | 12,250 | 6,750 |
| Heating capacity (35°F/0°F ambient) | | | | | | |
| Engine power (BTU/hr) | 12,000 | | | 14,000 | | |
| Electric power (BTU/hr) | 7,500 | | | 7,500 | | |
| Airflow: on high speed engine operation | | | | | | |
| Airflow volume @ 0 Pa static pressure | 1,500 ft ³ /min | | | 1,500 ft ³ /min | | |
| Weight (Condensing Unit): | | | | | | |
| Standard: cooling/heating on engine operation | 910 lbs | | | 947 lbs | | |
| With SmartPower electric standby: cooling/heating on engine/electric standby | 973 lbs | | | 1,010 lbs | | |
| Engine: 3 cylinder, liquid cooled | | | | | | |
| Model | TK 374 | | | TK 374 | | |
| Rating | 13.3 hp | | | 13.3 hp | | |
| Maintenance Interval | 2000 hrs | | | 2000 hrs | | |
| Compressor: lightweight aluminum alloy | | | | | | |
| Model | X-214 | | | X-214 | | |
| Displacement | 14 cu. in. | | | 14 cu. in. | | |
| Electric standby motor (option1) | | | | | | |
| Voltage / phase / cycles | 200 - 230 / 3 / 60 | | | 200 / 230 / 3 / 60 | | |
| Rating | 7.2 hp | | | 7.2 hp | | |
| Electric standby motor (option2) | | | | | | |
| Voltage / phase / cycles | 460 / 3 / 60 | | | 460 / 3 / 60 | | |
| Rating | 7.2 hp | | | 7.2 hp | | |
| Refrigerants: R-404A zero Ozone Depletion Potential (ODP), internationally approved | | | | | | |
| Charge | 5.7 lbs | | | 7.3 lbs | | |

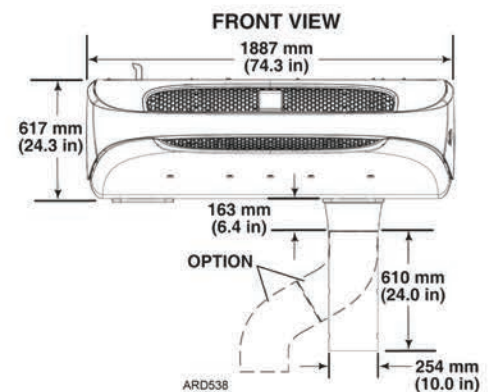
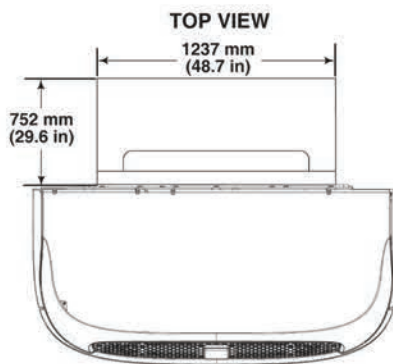
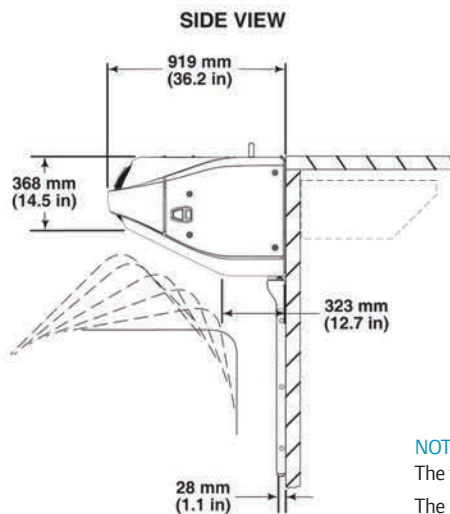

NOTE: The top of the unit to be mounted flush with the top of the cargo box when possible. The top of the evaporator to be positioned 25.4 mm (1.00 in.) below ceiling. The dimension from the top of the cargo box to the evaporator cutout will vary depending on the type of box, truck cab tilt clearance, etc.